

# Project Portfolio

Siddharth Kurwa

<https://skurwa.github.io>

# Contents

- Professional
  - Ball-Toss Machine, *M3 Design*
  - Automated Medical Device Cleaner, *M3 Design*
  - Crew Dragon Ocean Recovery, *SpaceX*
- Academic
  - Low-Cost Menstrual Pad Fabrication Device, *Mechanical Engineering Design Project (ME 266K)*
  - Smart Cart, *Projects in Mechanical Engineering (ME 377K)*
  - VeganEgg Scrambler, *Senior Design Methodology (ME 366J)*
  - CamSketch, *Robot Mechanism Design (ME 350R)*
  - Machine Shop Projects, *Machine Tool Operation for Engineers (ME 350)*
- Personal
  - Walking Mechanism, *Personal Project*
  - Quadcopter, *Personal Project*
  - Steering Design, *University of Texas Solar Vehicles Team*
  - Spindle Design, *University of Texas Solar Vehicles Team*
  - Hydroponic Garden, *Personal Project*

# Professional Projects

# Ball-Toss Machine

Performed electrical design, control programming, and prototyping to build an actuated and controllable ball-toss machine.

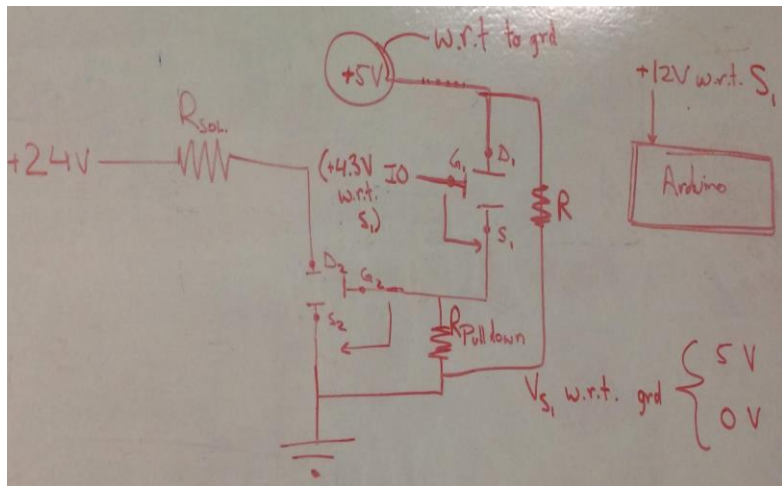

Whiteboarding of basic electrical design and control.



Surface-mount soldered 50+ circuit elements to PCB for ball-toss machine and programmed Arduino charge/discharge control.

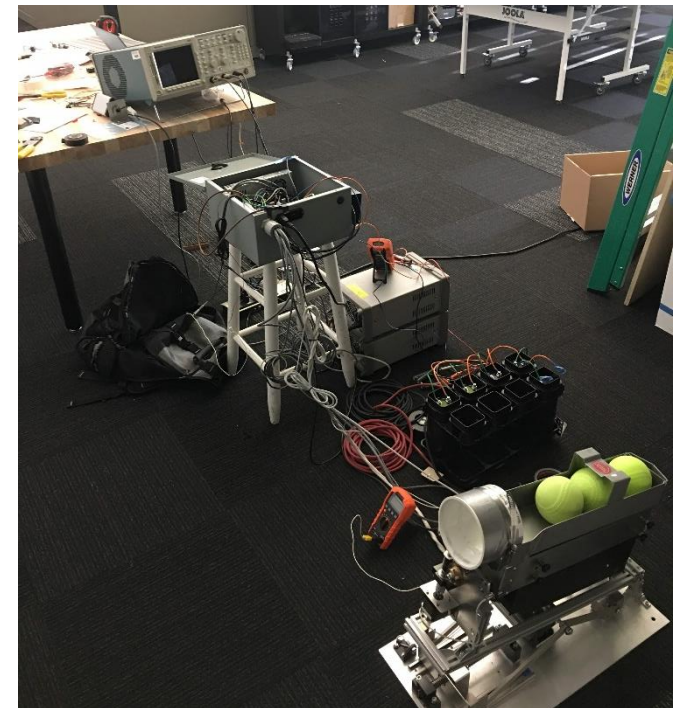

Debug and testing of prototype embodiment.

# Automated Surgical Handpiece Cleaner

Developed controls architecture, integrated software into physical system, and worked with mechanical and industrial design teams to achieve product specifications.

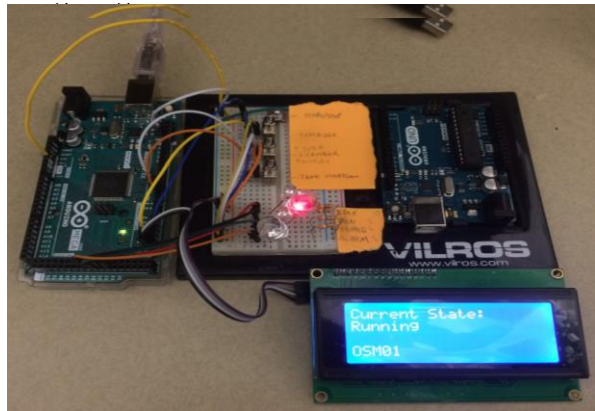
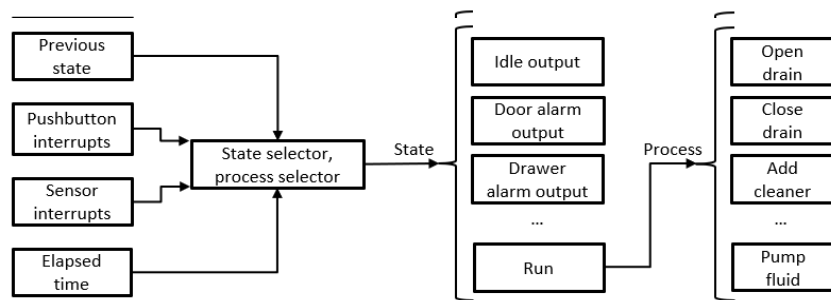

Initial hierarchical state machine architecture and proof-of-concept mockup.

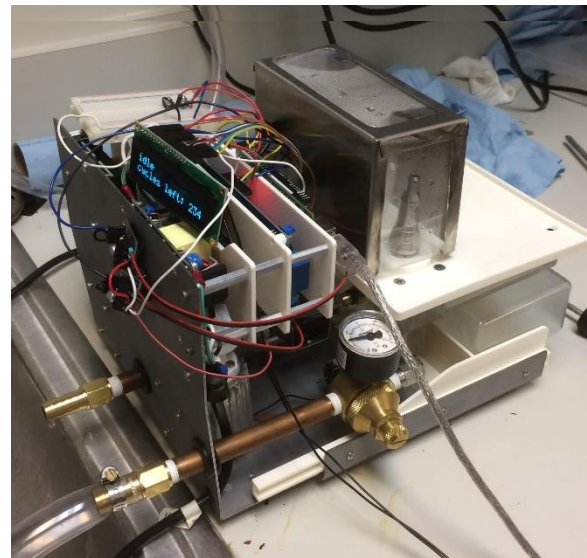

Integration, tuning, and debugging of control system with physical hardware (DC motors, sensors, valves, OLED display, and pushbuttons).



Incorporation of functional prototype into aesthetic shell and user interface.

# Crew Dragon Ocean Recovery

Designed, analyzed, and fabricated parts to support ocean recovery operation of Crew Dragon capsule.

Below image from the March 2019 Demo-1 mission depicts successful Crew Dragon hoist and ocean recovery.

Owned design, analysis, and ocean-testing of “horse collar” prior use on Crew Dragon Demo-1. The tool is intended to stabilize Crew Dragon (for capsule and astronaut safety) while maximizing recoverability of the capsule ablative (SPAM).

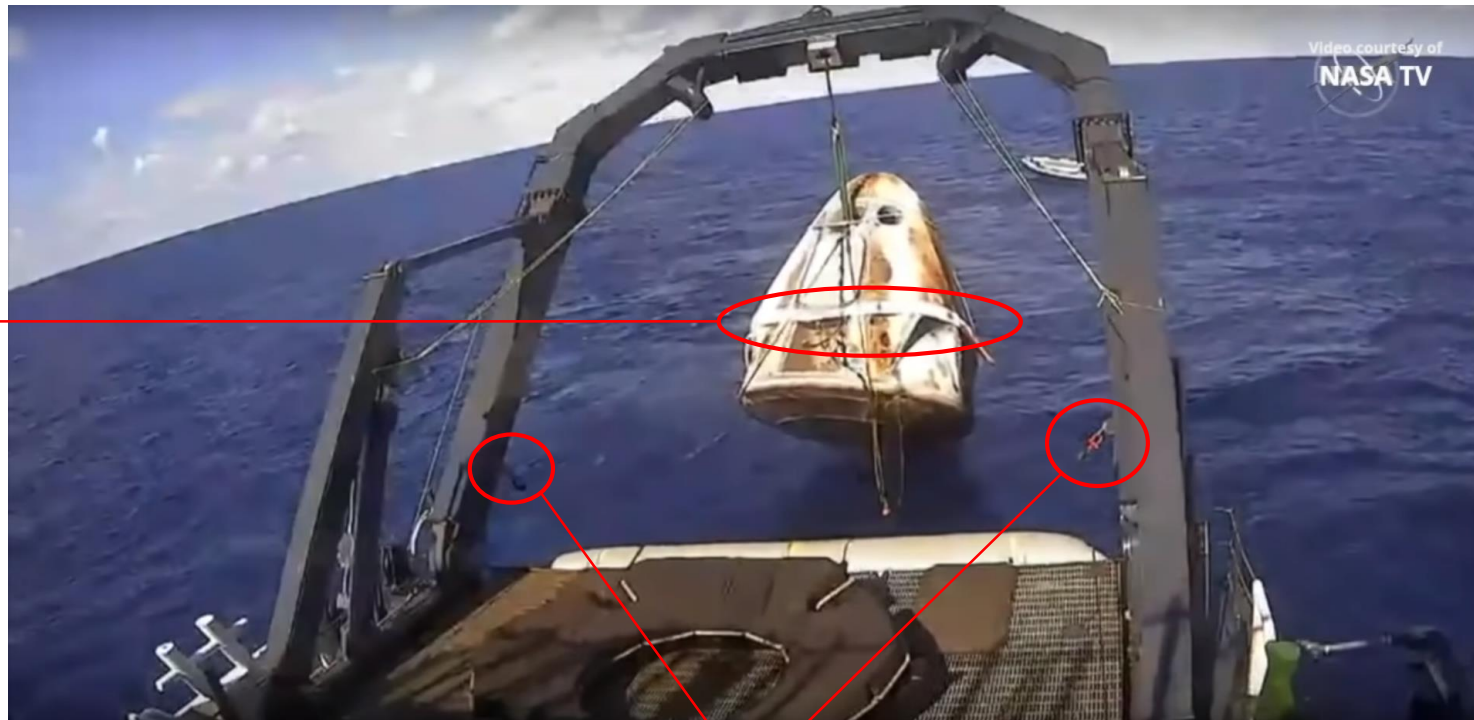

Designed, analyzed, and fabricated fairlead weldment used for hoist line routing (not pictured).

Designed in Siemens NX, analyzed in ANSYS, and fabricated lug weldments on vessel's A-frame.

# Academic Projects

# Low-Cost Menstrual Pad Fabrication Prototype

Led team of 4 to develop a functional prototype process to enable Syrian refugees to locally fabricate low-cost menstrual pads.

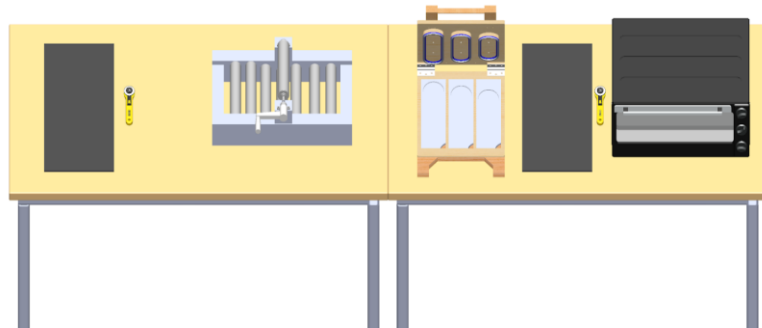

Developed complete manufacturing process from raw material to finished, usable product.



Led design and prototype of size-customizable thermoplastic heat sealer.



Ordered, tested, and selected suitable fabrics to scale low-cost menstrual pad fabrication. In June 2019, 500+ pads were produced for use in Beirut refugee camp with unit cost less than \$0.12.



# Smart Cart

Independently designed, analyzed, and prototyped the mechanics, electronics, and software of an autonomous shopping cart.

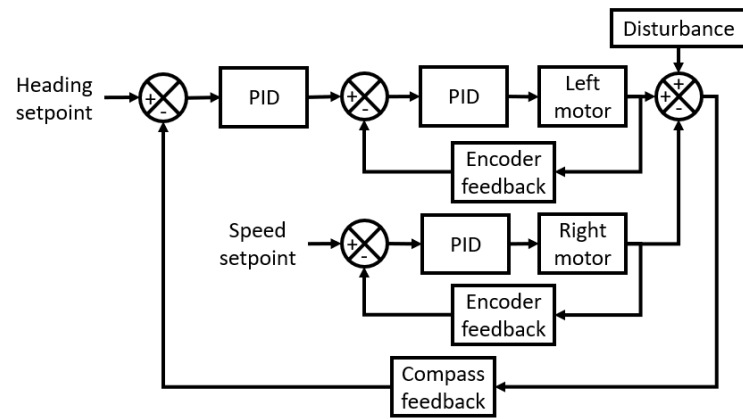

Designed control system architecture for closed-loop obstacle avoidance, steering, and speed control.

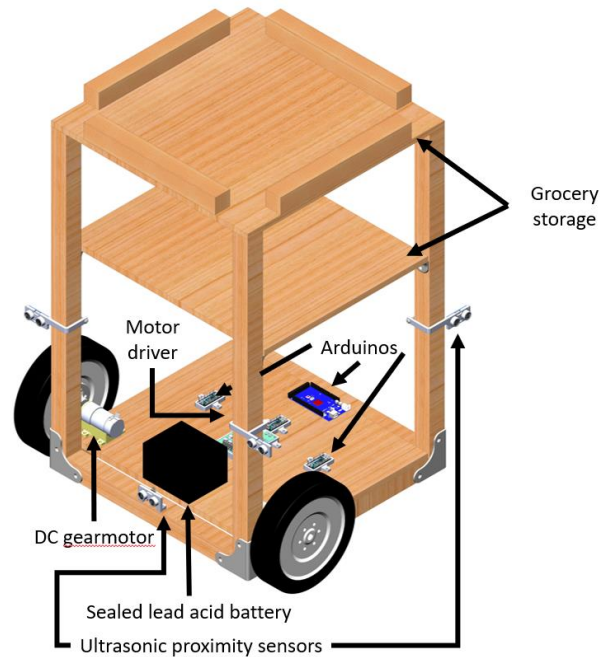

Mechanical cart design in SolidWorks.

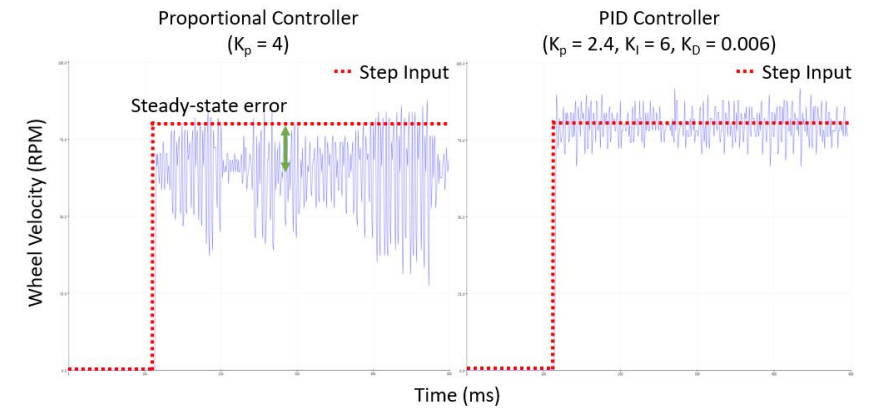

Used Ziegler-Nichols tuning to tune PID controller.

# Failure Analysis of a Rocker Arm

Worked with team of 3 to analyze metallurgical properties, fractography, and loading to determine cause of rocker arm failure in 2015 Chevrolet Cruze 1.8L engine.



Failed rocker arm.

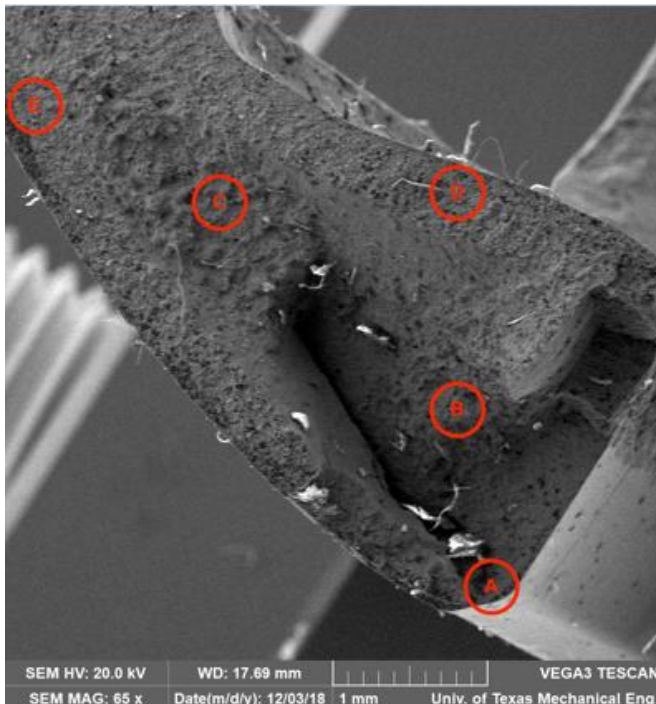

Used SEM to observe micro-mechanisms at 5 locations to identify brittle failure (intergranular fracture).

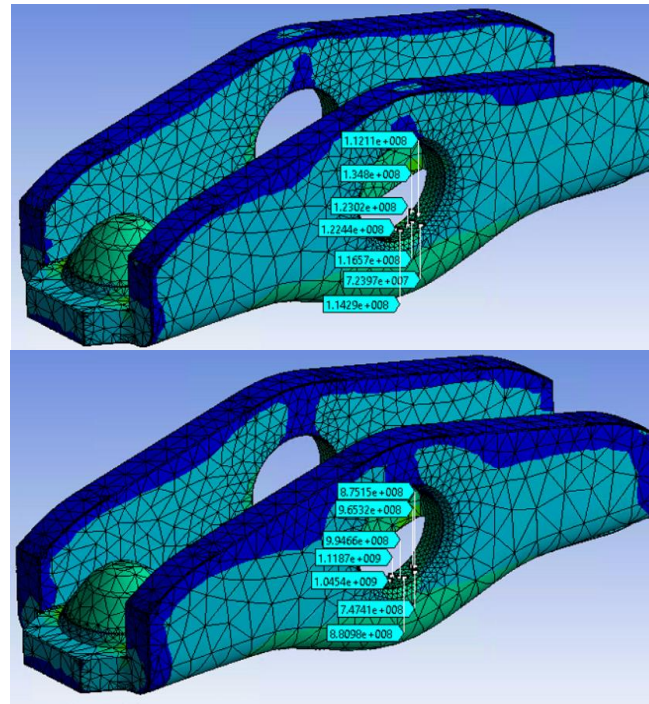

Estimated principal stresses at failure origin under normal operation (top) and overload using ANSYS static structural (bottom).

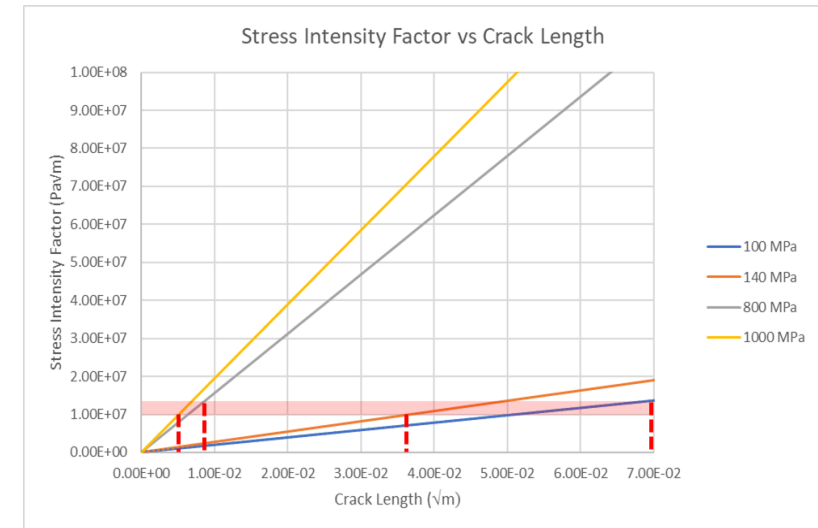

Determined necessary edge defect size for fracture under estimated stresses to approximate cause of failure based on linear elastic fracture mechanics.

# VeganEgg Scrambler

Led team of 6 to develop a semi-automatic prototype that whisks and scrambles a VeganEgg (egg substitute) to completion while monitoring changing consistency and temperature.

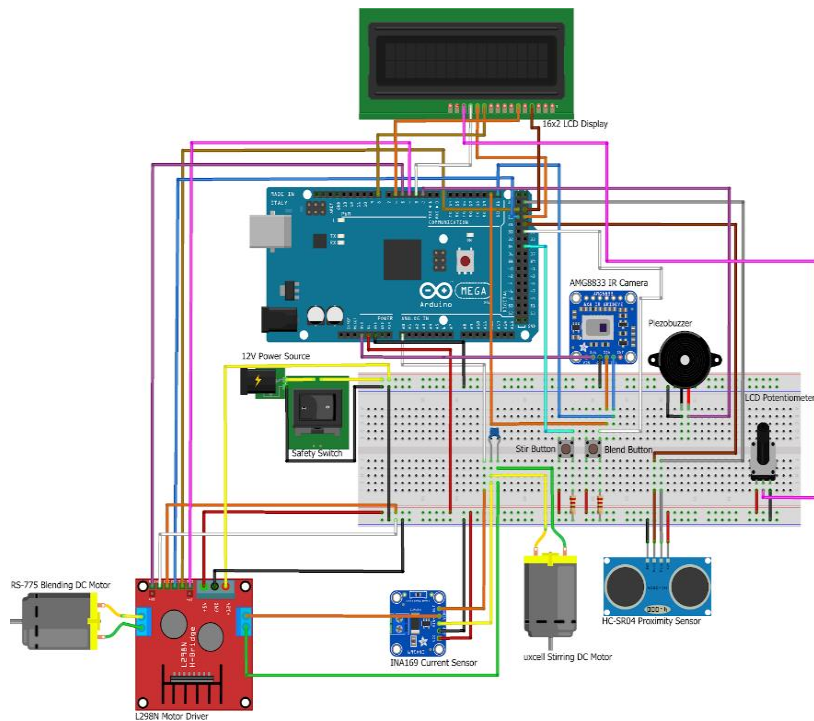

Executed electrical and software architecture design, implementation, testing, and debug.

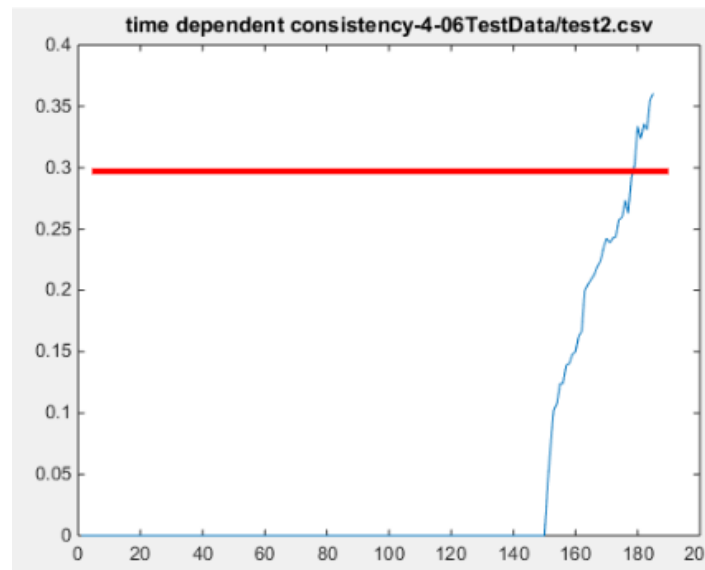

$$con_i = con_{i-1}(1 - W) + [\min(\overrightarrow{cur}_i)(1 - \frac{t_i - t_0}{300}) + \max(\overrightarrow{cur}_i)(\frac{t_i - t_0}{300})]W$$

$con$  = consistency  
 $cur$  = current  
 $t_0$  = initial time  
 $W$  = filter weight

Formed an empirical model for egg consistency using cooking time and motor torque by fitting test data.

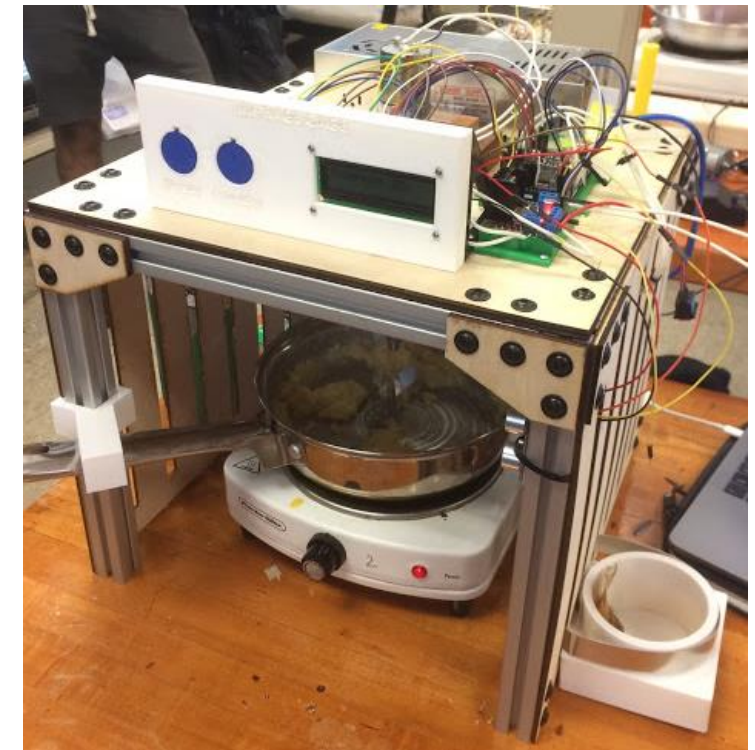

Delivered successful prototype under budget and on schedule.

# CamSketch

Led team of 3 to develop an accessible sketching mechanism for motor-impaired elementary school art students.

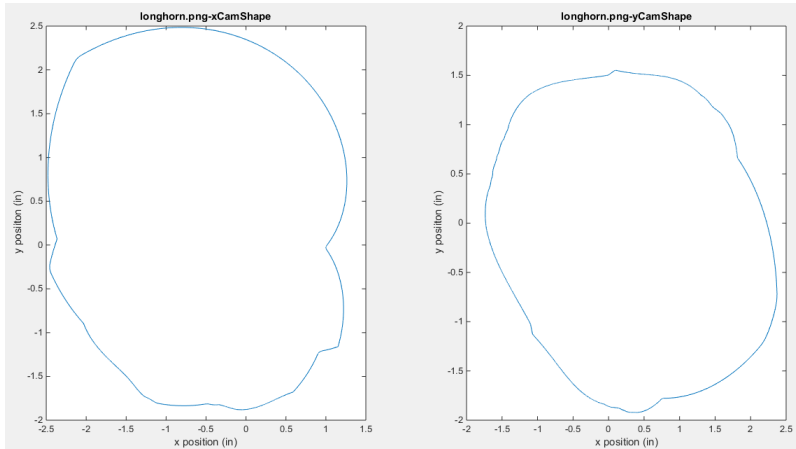

Wrote MATLAB function to generate cam profiles from an input image of a shape.

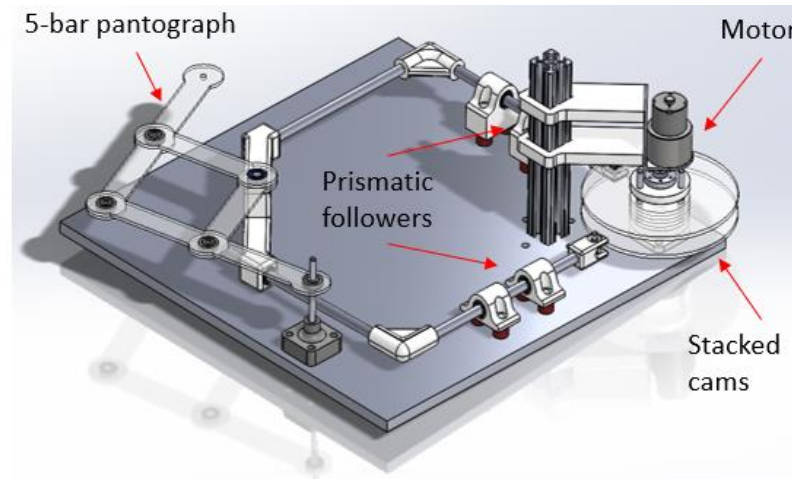

Collaborated with team to design and revise mechanical system in SolidWorks.

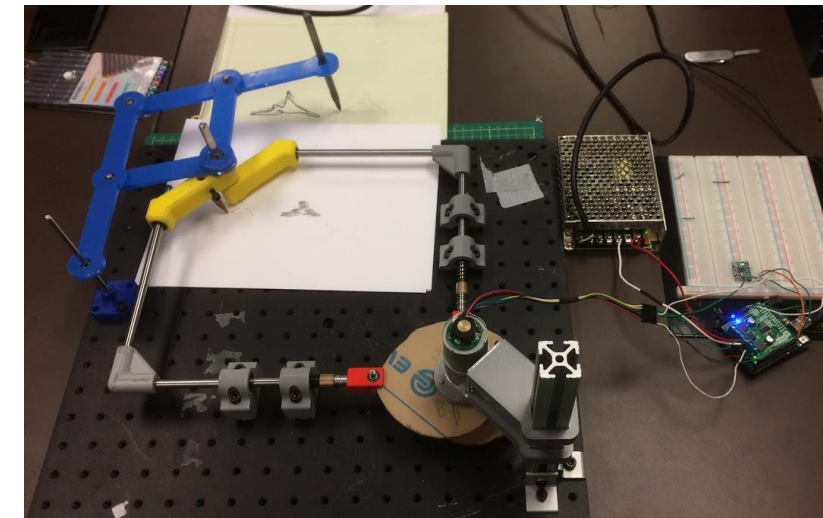

Iterated through two rounds of prototyping to successfully achieve and demonstrate functional system.

# Machine Shop Projects

Performed projects to become familiar with machine shop equipment and basic manufacturing methods.

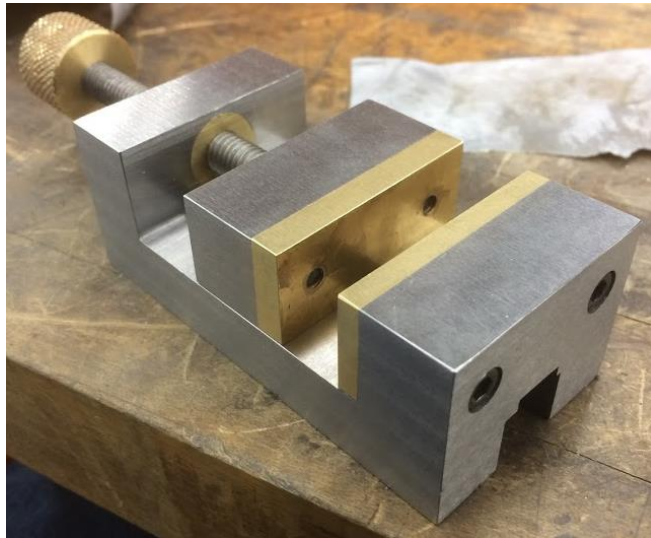

Manufactured 9 steel and brass parts with a manual mill, manual lathe, and a CNC mill and finished with a surface grinder.



Lost-foam casting of a mountain in aluminum.

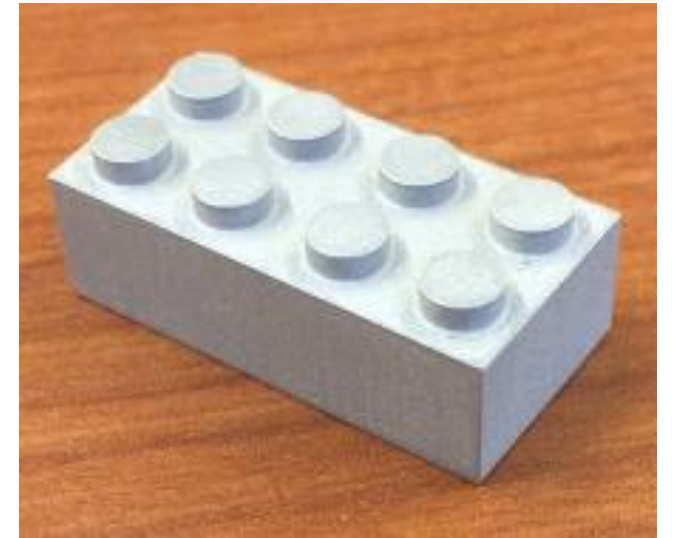

Generated toolpaths in Mastercam, CNC-milled, and beadblasted an aluminum Lego brick to scale.

# Personal Projects

# Walking Mechanism

Designed and prototyped a walking mechanism inspired by Theo Jansen's Strandbeests.

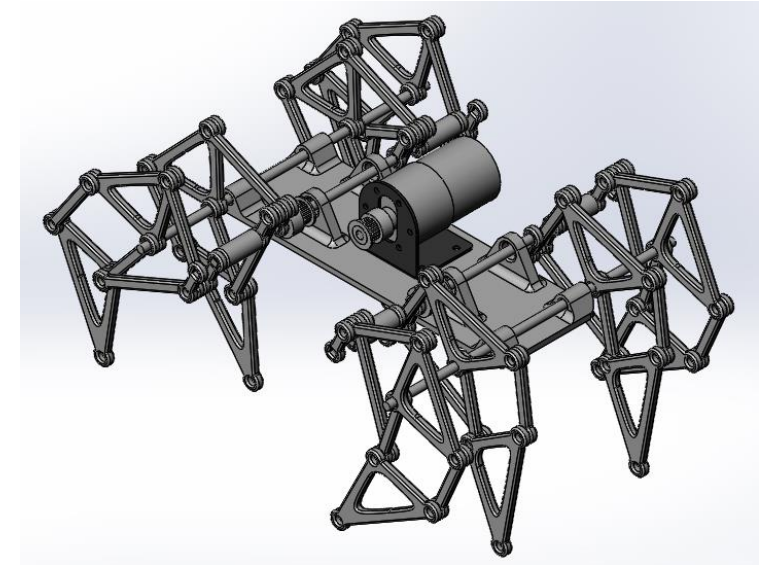

Mechanism design in Solidworks uses 8 Jansen's linkages, 2 belt-driven shafts, and 1 motor to walk.



Prototyped test parts to optimize geometry for interference and slip fits.

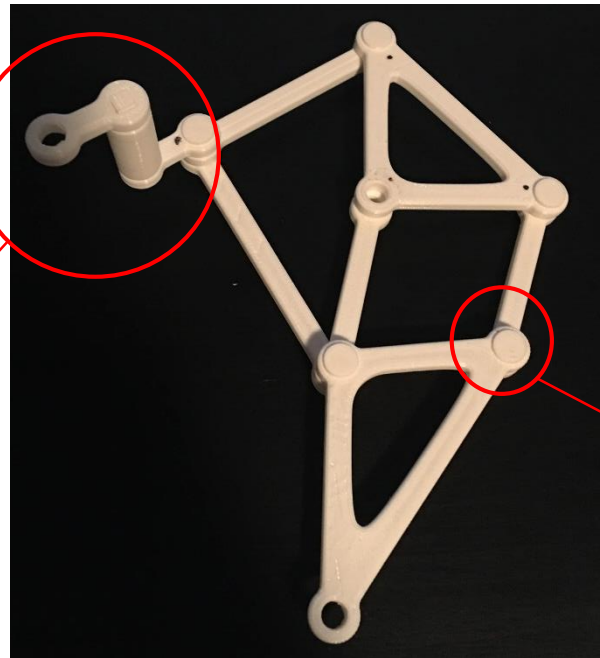

3D-printed Jansen's linkage.

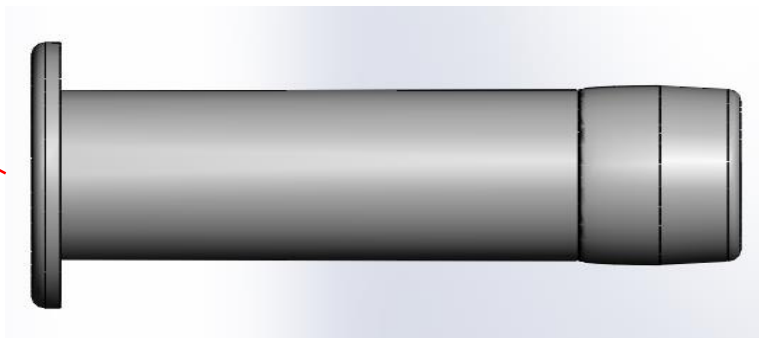

Detent on pin-end to create interference fit with outer link, easing assembly while maintaining a low-friction slip fit bearing surface.

# Quadcopter

Designed, 3D-printed, and assembled mechanical assembly and supported controls development and testing.

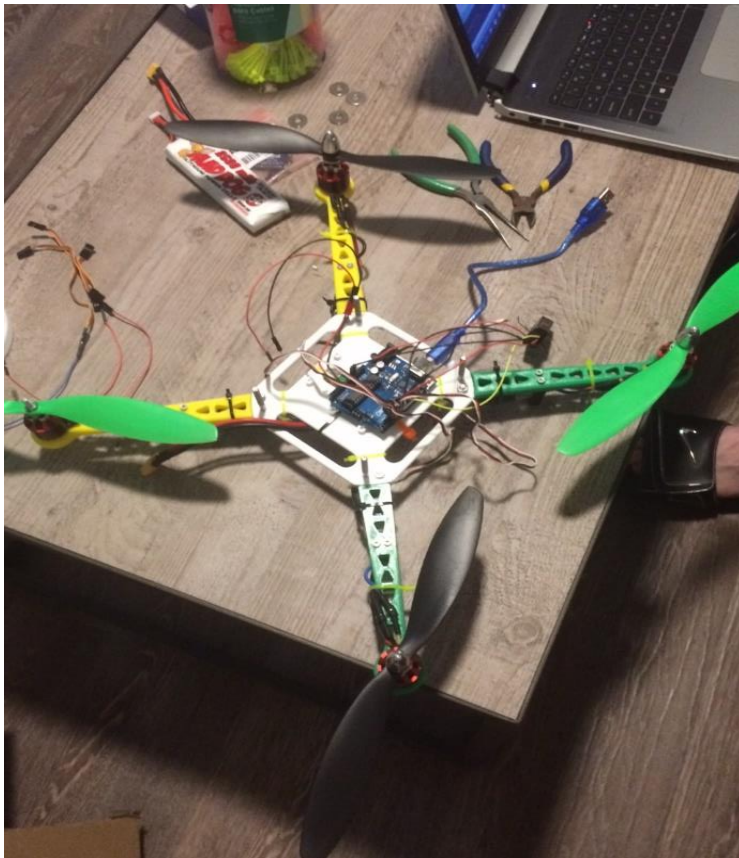

Designed and prototyped mechanical assembly.



Test stand for PID and motor trim tuning.



# Solar Vehicle Steering Design Tool

Developed a dynamic tool to model the steering system geometry for the Solar Vehicles Team.

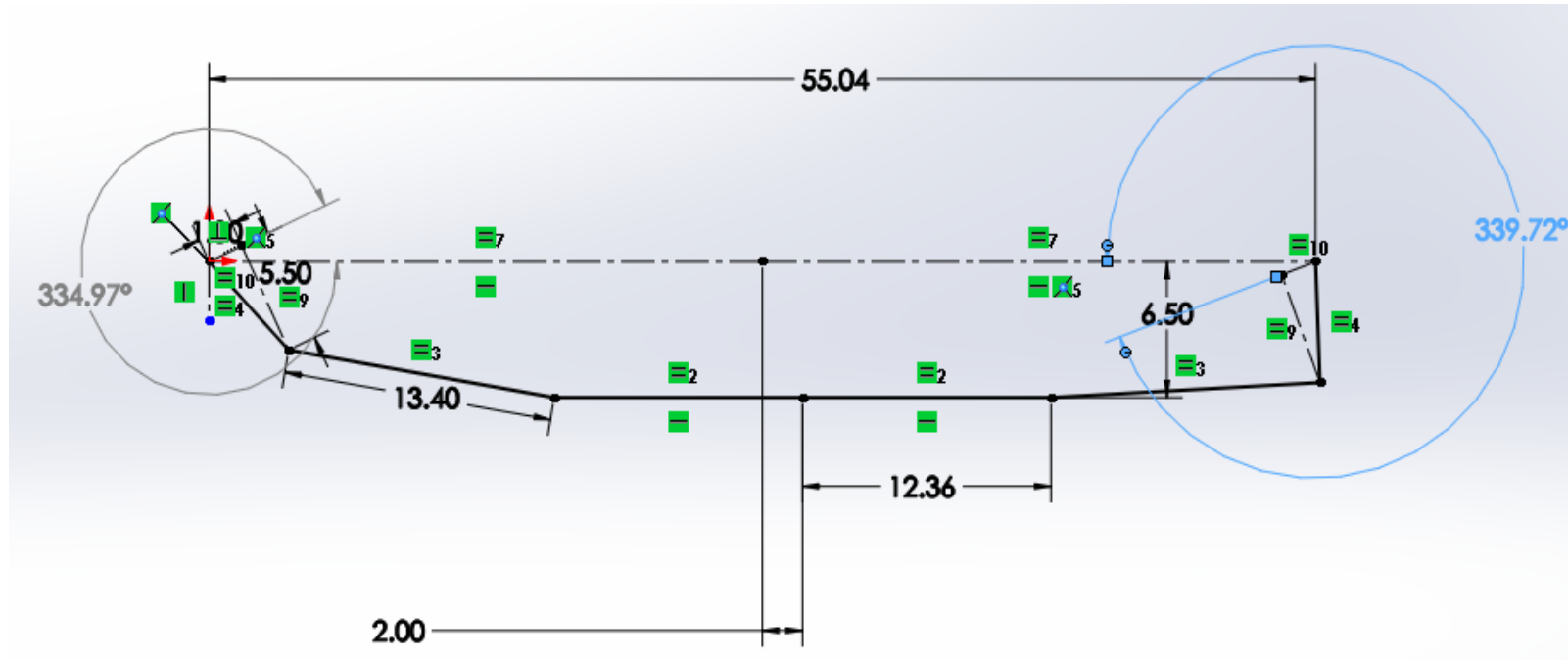

Solidworks sketch to model Ackermann steering linkages in order to properly specify required link lengths and pinion travel to achieve desired vehicle turn radius.

# Solar Vehicle Spindle Design

Designed lighter spindles for the Solar Vehicles Team while satisfying structural loading requirements.

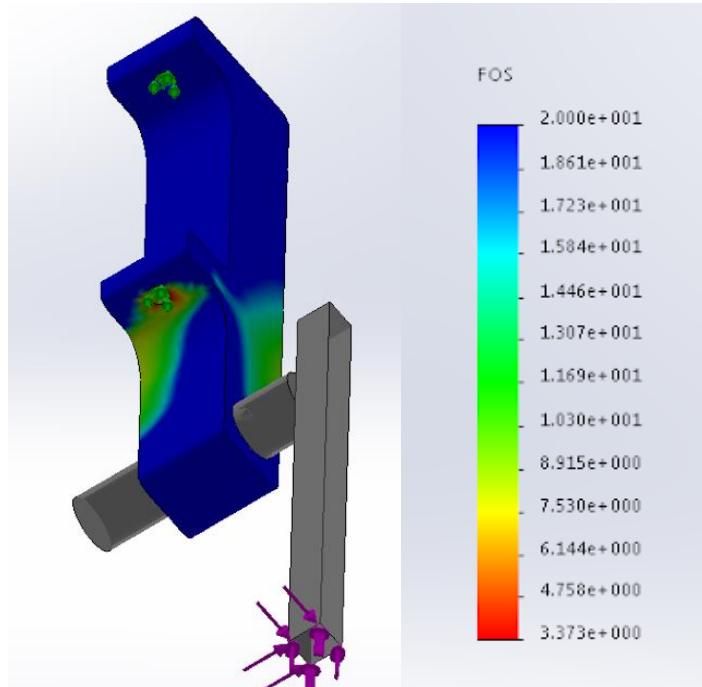

Used Solidworks static simulation to iterate through designs, optimizing for safety factor and weight.

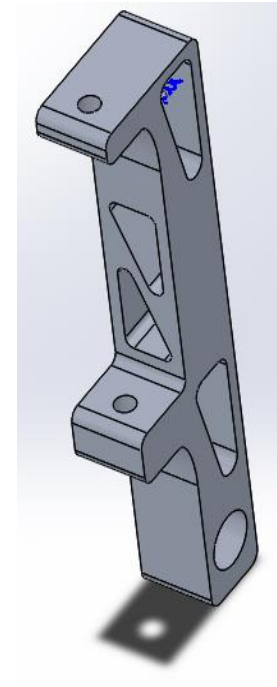

Final spindle design in Solidworks with a 3.13 lb weight and a 3.1 minimum safety factor to yield.

# Hydroponic Garden

Designed and built a continuous flow, low maintenance gardening system.

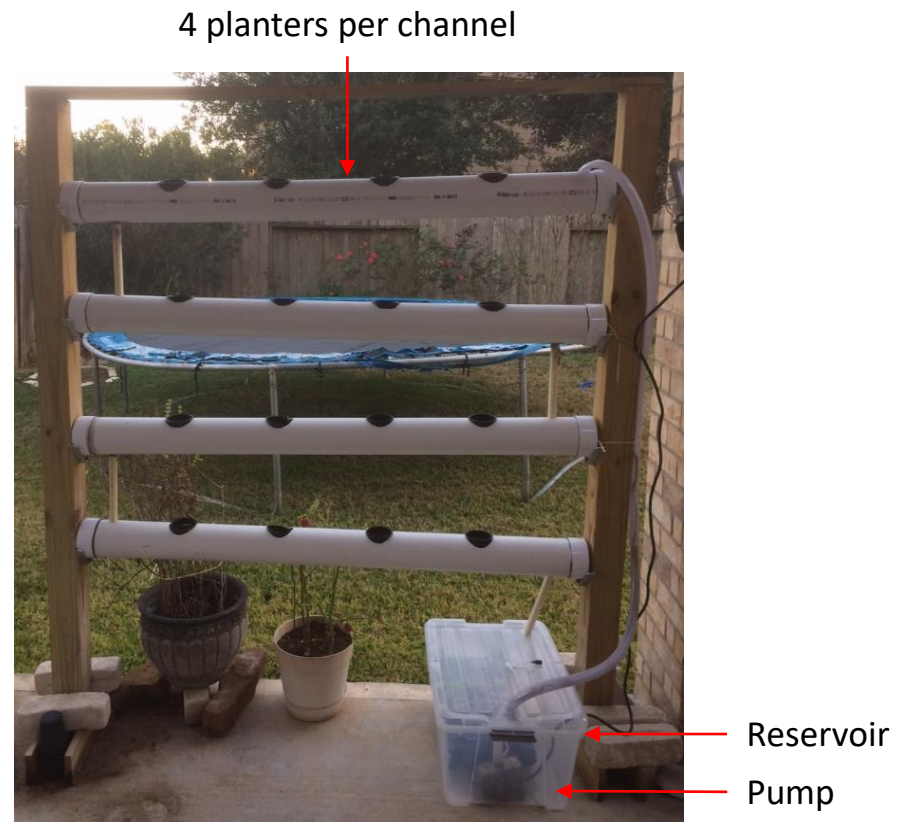

Calculated pump size and max allowable channel angle to achieve desired flow rate. Then, spec'd parts and built functional system.